

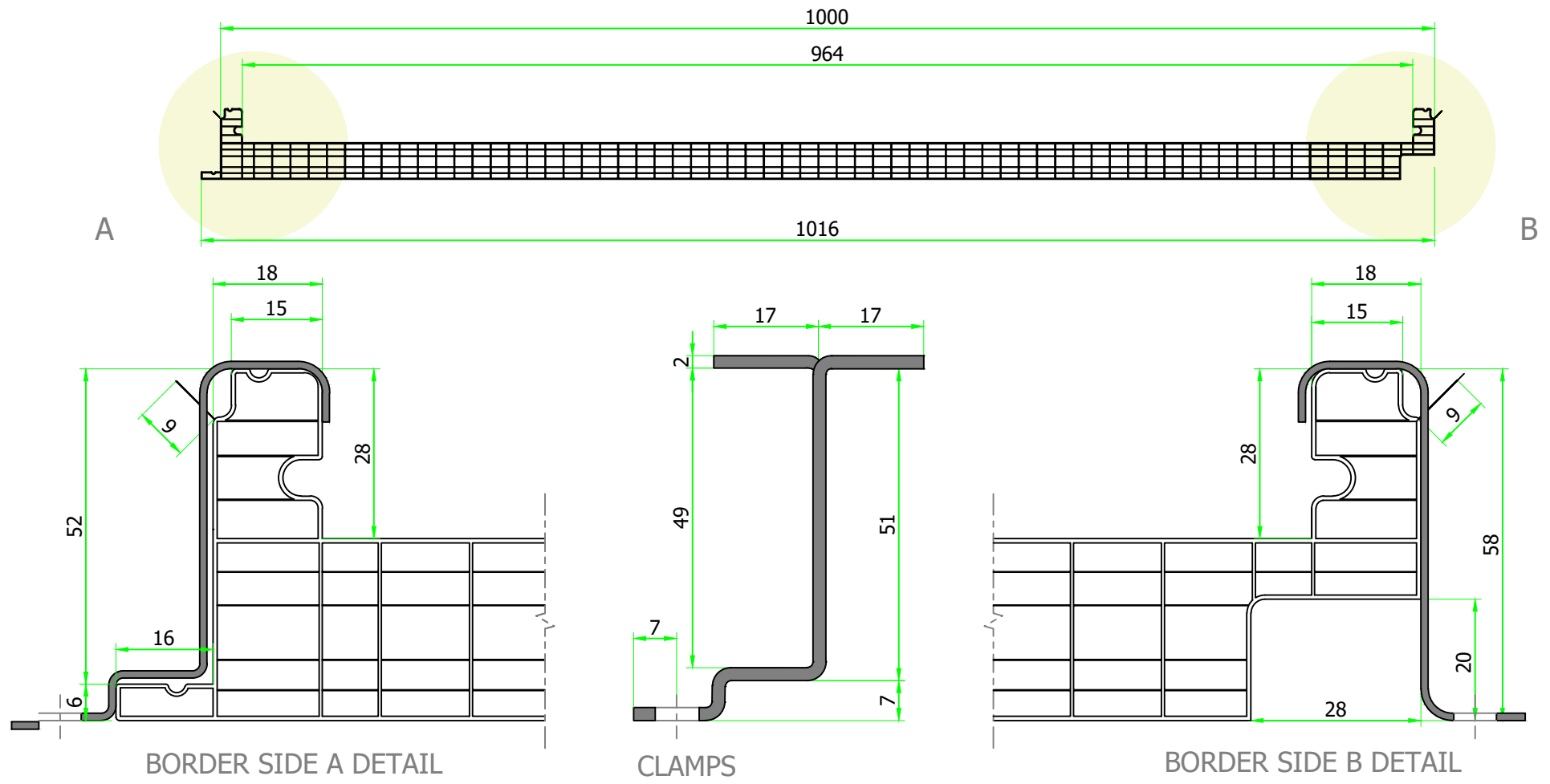

## CONTINUOUS POLYCARBONATE PANEL COVER HIDDEN SCREW NOVAMETAL 30 MM COMPLETE DETAIL GEOMETRY

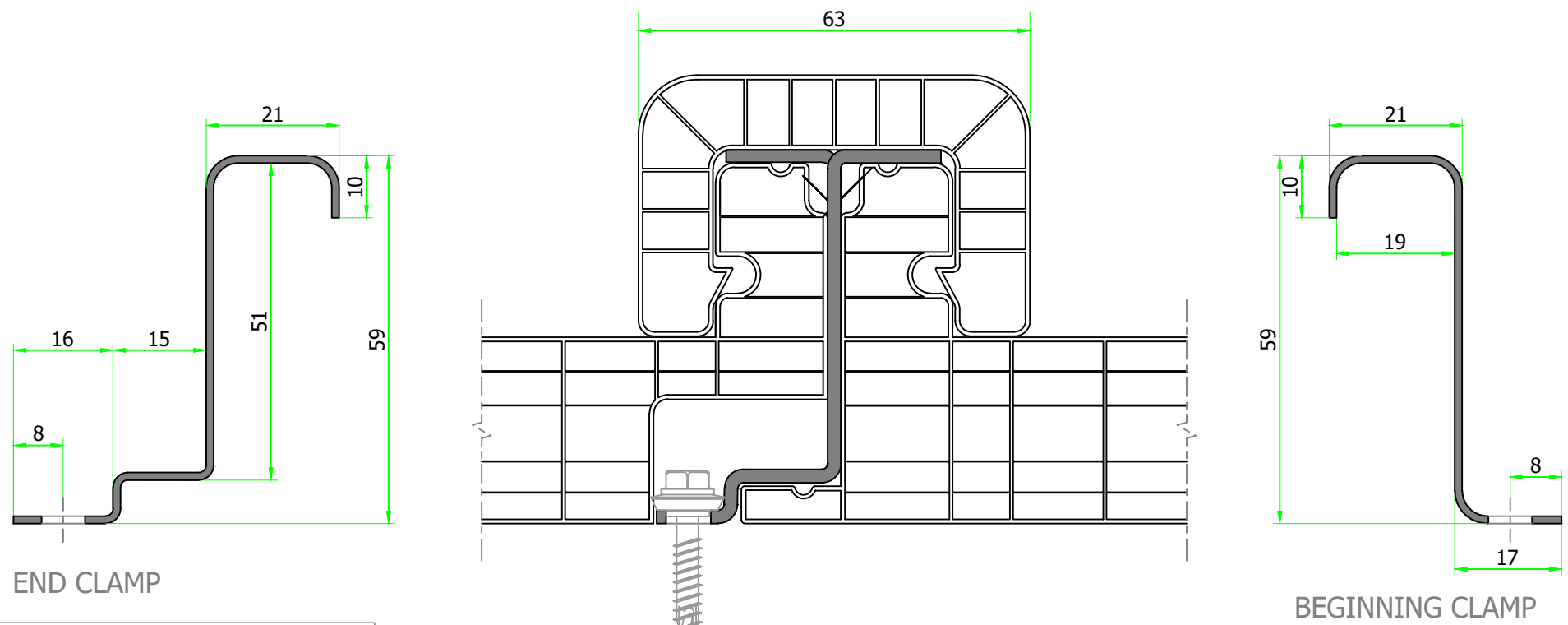

## FITTING DETAIL WITH POLYURETANO/POLYISOCYANURATE PANEL OF 30MM



CHARACTERISTICS	
Vertical cells space:	15 mm
Horizontal walls:	6
Effective width:	1.000 mm
Length:	custom-made
Solar Control (G value):	Neutral • 68%
	Opal • 59%
Light transmission:	Neutral • 6 %
	Opal • 39%
Thermal transmittance:	1,26 w/m <sup>2</sup> . °C
Noise insulation:	~ 21 - dB
Expansion:	0,065 mm / m· °C
UV protection:	outer face coextrusion
Fire rate:	<b>B-s1, d0</b>
	(UNE-EN 13501-1:2007)
Operating temperature:	-30 +120 °C

LOADING TABLE (kg/m <sup>2</sup> ) Two or more supports														
Distance between supports (m)	1,00		1,25		1,50		1,75		2,00		2,25		2,50	
	pressure	suction	pressure	suction	pressure	suction	pressure	suction	pressure	suction	pressure	suction	pressure	suction
NOVA 30 mm	487	76	277	61	174	51	118	43	96	42	80	41	68	40
NOVA 40 mm	608	84	346	67	218	56	148	48	120	67	100	46	85	45

\* The tables have been obtained based on the experimental results determined by the external laboratory of the Department of Mechanics of Continuous Media and Theory of Structures of the University of Seville.  
 \* Maximum load values, uniformly distributed in kg / m<sup>2</sup>, with a limitation of the Service Limit State of deformations of L / 50 for pressurized loads, and system breaking load values for suction loads.  
 \* The designer must verify the effective loads that will act on the system, as well as the safety coefficients that must be applied taking into account the characteristics of the place and the structure in which the polycarbonate panel will be integrated.

The values of the suction loads indicated in the following table have been calculated for a 1.2 mm thick steel clip per belt. If higher suction performance is required, there is the possibility of fixing with a 2 mm thick staple that increases the resistance of the system. To calculate the value of this load with the 2 mm thick staple, a coefficient of 2.32 must be applied to the suction values provided in the following table.

All units of measure indicated in this plan are indicative and subject to logical production tolerances. Both in length and weight.